

ISSN: 1118-5872



FOS

MULTI-DISCIPLINARY

JOURNAL

(Alvan Ikoku Federal University of Education)



ENHANCED AUTOMATIC FLOOR-CLEANING-ROBOT USING ARDUINO NANO AND IR SENSOR

Emelike Chinaenye D¹, Emelike Ogechi V¹, Okorie Simon C (PhD)¹,
Onwukwe Ernest O (PhD)², Okafor Chidozie Raymond Patrick¹., Odoemene Ijeoma O.¹

¹Computer Science Department, Alvan Ikoku Federal University of Education, Owerri

²Integrated Science Department, Alvan Ikoku Federal University of Education, Owerri

email: chinaenye.emelike@alvanikoku.edu.ng; ORCIDiD:0009-0006-0204-7314

08068089702, 08033114061, 08037453637,08034801763,08034980234, 07067991975

Abstract

In this twenty first century, robots are being used comprehensively in almost all fields of life, especially in such areas as hazardous, boring and repetitive routine tasks. Cleaning the floor from dusts is one of the routine activities done at home, offices shopping complexes daily. While cleaning is still done manually by maids, janitors or individuals, it still exhausts and stresses out the person doing the cleaning. Hence the need to develop an enhanced floor cleaning robot. Robots are deliberate computerization of devices to do simple job effortlessly reducing human effort. The main purpose of this project is to design and implement an automated floor cleaning robot to make cleaning process easier, cleaning the floor based on the instruction given by the user thereby providing a solution with minimal cost, user friendly, fast, efficient and save labour. The main objective of the project is to design and implement a prototype control system enhanced automatic floor cleaner controlled by Arduino Uno microcontroller and IR Sensor to achieve the aim of this project. The complete circuit can be powered by battery. With the configuration of the code based on data input, and switching on the power and buttons, the device performs functions like moving in different direct as instructed cleaning the floor.

Keyword: Arduino, IR sensors , LCD display, Cleaning robot, Android Phone, Motor Dc

Introduction

Cleanliness is the act of cleaning, beautifying comfortable environment. Cleanliness include in the home, office or work place, schools, market, health centres and general environment. Hence cleanliness so important in human day to day lives. The job of cleaning the floor of the above mentioned places consume a lot of energy and time.

Automated devices make tasks it is used for to become labour-saving as well as time saving. Different automated floor cleaners can be seen and bought from the market, but some locally produced can be more efficient and convenient for the user especially those with mobility issues. Automated floor cleaning device or Cleaning robots are used in the domestic and industrial cleaning and most of the ones in the market require plenty of efforts to manipulate the cleaners. These critical issues made it possible for researchers and engineers to design robots that are capable of assisting in the cleaning of the environment with less stress. The research and development of an enhanced mobile robot with mobile phone control prototype which can be used for floor cleaning is not a small task. In order to handle this task and complete it within a space of two months is not feasible. Hence some generalization and suppositions were made to the designer's original ideas of having an 'ideal' enhanced

automatic floor cleaning robots. By so doing, some functional requirements that would improve the robot performance were not taking into account due to their characteristic complexity or due to their mechanical effect. The enhanced automatic floor cleaning robot using Arduino technology has implanted technologies. Robots are used to decrease the human intrusion and work spontaneously. They are more efficient, precise and able to work without being tired. Robots are used in various fields. The enhanced robot shall be controlled by Arduino controller as the brain of the robot while the infrared Sensor make the robot automated and able to detect obstacles (IJIERT, 2017).

Problem Statement

Certain difficulties are likely to occur while cleaning the floor such as human error or systematic error. To clean every corner thoroughly, we need to design a robot that can clean manually and or automatically.

Secondly, the busy life style of the urban dwellers makes it difficult to meet up with the cleanliness of the house, offices and others. In such cases, one will look for ways of meeting the challenges.

Normally, the floor is cleaned using dry or wet mop (hand based or tool based).

Solution

In the case of saving time in cleaning the house or office, a cleaning enhanced Automatic cleaning robot will be an ideal solution to that.

An enhanced automatic cleaning robot will reduces stress and much time used in such cleanings.

Manual or human work will be taken over by robot technology and applications.

Research issues

This research involve the review and analysis of recent design and implemented work characterized as Artificial Intelligence and sensors in Robotics as they consider the major issues in robot design; Action and perception. This is carrying out the cleaning, and identifying obstacles and making decision to overcome it.

Review of Related Literature

Microcontrollers - Arduino

Currently, there has been an increase in number of developed applications using microcontroller with a variety microcontroller development cards used in making such systems and used in different projects in the university. Microcontroller has large number of hardware and software support , however, there are many different types of microcontroller and development cards in the market. It must be noted that in the words of Güven, Y., Coşgun, E., Kocaoğlu, S. Gezici, H, Yilmazlar, E. (2017), ‘that university students don’t have the basic concepts of microcontrollers making it difficult for selecting necessary hardware for implementing projects involving microcontroller’. Many of these systems, which are open source, are becoming more and more popular. Linux, Android and Windows, as well as its own operating systems, automation and control systems, as well as image and signal

processing can perform many functions. It is aimed that this work will be a guide for newcomers to microcontrollers and embedded systems (Güven et al, 2017).

A microcontroller is a small computer that has with input / output (I/O), it allows operations of precise control of devices. It doesn't have the ability to manage complex processes, yet they are low cost and small and they are widely used in quiet a variety of electronic devices for embedded system. Microcontrollers have attracted attention as it is seen as an essential tool for creating the internet of things (IoT) (Wonsuk, 2018) and Anene, Ibrahim & Abdulhameed, (2021). Microcontrollers can be use to design devices turn robots as clearly stated by Tiwari, Kotecha, Rasal, Shukla, & Mandavkar, (2017) that 'These robots operate semi- or fully autonomously to perform services useful to the well-being of humans and equipment'. Güven, 2017 also sees a microcontroller as an integrated circuit that is housed within each component that can perform necessary operations and that can perform a precise task routinely without requiring another thriving. It contains a microprocessor, memory units and input-output interfaces, analog-to-digital conversion (ADC), pulse width modulation (PWM) and various control and communication modules.

Microcontroller and Automated Floor Cleaner

According to Rathee, Jalan, Nandwani & Sharma, (2020), the electronic circuitry made up of microcontroller on which the software program is directly loaded makes the device a robot which consists of the HC-05 Bluetooth module which sends the command to the microcontroller. This microcontroller controls the action of the entire motion, deciding the way in which the entire set up should turn depending on the presence of any obstacles. A microcontroller is a low-cost, programmable computer without any peripherals, like, keyboard, mouse or monitor. Microcontroller boards can receive instructions as input and output the outcome through the pins of their processing chips in such a way that users can directly read from sensors and perform actions (Arulananth, Baskar, Hari, Divya, Sanjana & Bhavana, 2020). Microcontrollers execute detailed tasks which can be used in domestic machines, medical appliances, cars, and other systems and devices.

There are several microcontrollers that can be used as a robot floor cleaner. Arduino Uno and Arduino Nano can be said to be one of the commonest microcontroller that can be used to make robotic floor cleaner as this project demands.

Arduino Uno (ATmega328) is one kind of single-chip microcontroller formed with Atmel within the 'megaAVR family'. The architecture of this Arduino Uno is a customized Harvard architecture with 8 bit RISC processor core. Some other form of Arduino board include Arduino Pro Mini, Arduino Nano, Arduino Due, Arduino Mega, and Arduino Leonardo.

ATmega328 can be said to be one of the most popular microcontrollers in the world, and it has always been the microcontroller of choice for many designers (Yuda, Muhandi, Rian & Roni, 2021).

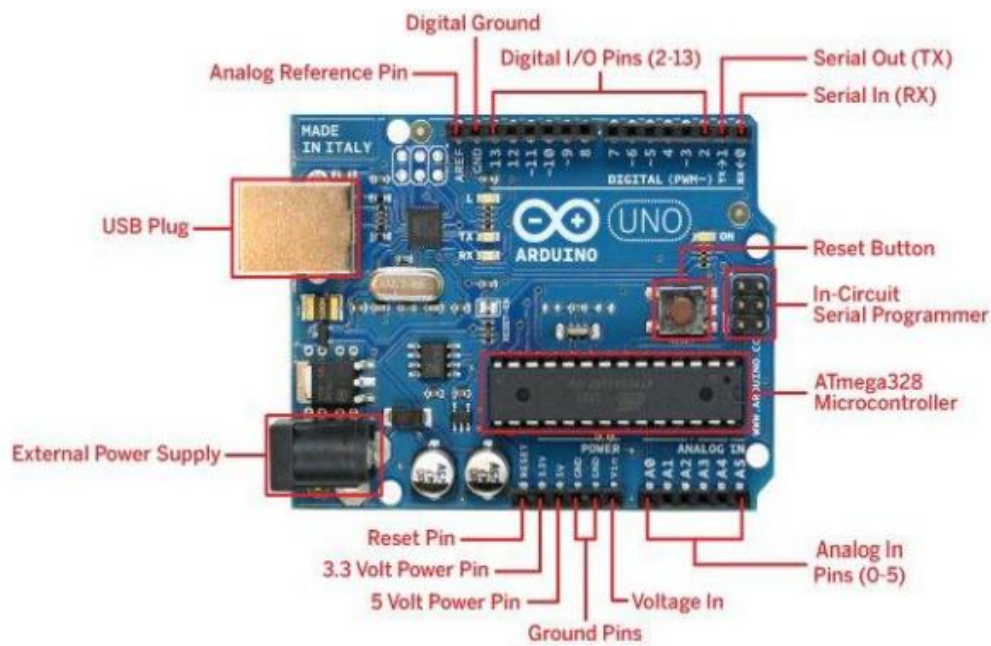

Figure 1: Arduino Pin configuration parts

The complete floor cleaning robot can be divided into different parts such as Sensors – infrared (IR) Sensor for detecting obstacles, Motor Shield L298, Dc Motor for movement Arduino Uno microcontroller (Arduino Nano), Servo.

The floor cleaning Robot is a form of Artificial Intelligence (AI) using Sensors to work automatically without human interferences. It operates when the Arduino Uno/Nano microcontroller processes the sensor as an obstacle detector and a DC motor as a robot driver, then the DC motor is driven by the Motor Shield L298.

Most of the Arduino boards work in the following stages:

- With a program is already fed into the Arduino board IC to perform a certain task.
- The controller receives inputs from the IR sensors and the Push button signals.
- The signals are analyzed .
- For example, if the input signal is received as 0111, then the chassis is destined to do forward movement. So signals are sent out to the driver board accordingly.
- In case of the IR sensors, the signals when received are supposed to stop the motor. Thus no supply signal is given to the motor.
- The program is fed into the arduino board through software specially designed for this board.
- The software is ARDUINO IDE that can be installed in any system with its basic configuration.
- The output from this goes to the motor driver board.
- The processor used here is ATMEGA 328D.

The foremost role of this processor is to decode the information gotten from the pushbuttons and the IR sensors, and then send the signals to the motor driver board for actuation of the motors. The Arduino Uno/Nano has 14 digital input/output pins (of which

6 can be used as PWM outputs), 6 analog inputs, a 16 MHz ceramic resonator, a USB connection, a power jack, an ICSP header, and a reset button. It contains everything needed to support the microcontroller; simply connect it to a computer with a USB cable or power it with an AC-to-DC adapter or battery to get started. “Uno” means one in Italian and is named to mark the upcoming release of Arduino 1.0 version. The Uno and version 1.0 will be the reference versions of Arduino, moving forward. The Uno is the latest in a series of USB Arduino boards, and the reference model for the Arduino platform.

Hence, an Enhanced floor cleaner is an electronic device that is logically programmed to clean a given surface with the use of technology based microcontroller called Arduino. It involves some feature that can be observed in smart floor cleaners such as wet mopping or vacuum cleaner capable of detecting obstacles. According to Uman Khalid et al, (2015) an enhanced floor cleaner operates on dual mode (manual and automatic). In the case of manual, the robot can clean a given space via laptop GUI Visual Studio through Bluetooth connection. In another research, Shinde, Shrivastava, Sharma & Kumar, (2013) developed an android based application robot driven by a microcontroller. Their idea was to show that an android app can be controlled using a different electronic devices. They developed communication between smartphone and a robot via a Bluetooth. Thakur et al, (2018) opined that technology had continued to evolved from time to time unlike in the traditional cleaning method that involved different handmade instruments. They also referred to vacuum robots where made up of electric energy as at 2016, 2017 but are currently made of automated devices such as microcontroller. Their multi-function auto cleaner was basically a smart design which was intended for use in small hospitals and clinics and can operate wet and or dry cleaning.

According to Chen G. et al.(2011), Varsha. P.H et.al.(2018) and Hendriks, B. et al, (2011), enhanced automatic floor cleaners can undertake sweeping, others can accomplish mopping while few other can handle dry and wet floors mopping. While some as a robot can be controlled by the use of Bluetooth linked with smartphone or android based device (Subankar, Tashi & Rajesh, 20016).

While the research of Akash, Ishant, Lakshita & Tanya, (2020), indicated that an automated floor cleaner can be controlled by a GSM device.

Uman Khalid et al, (2015) developed an automatic and manual (dual mode) automatic floor cleaner based on using sensors to control of the robot to clean the surface using laptop or computer to control it. On the other hand Namita, Shreya, Vineet & Samarth, (2013) developed one using an android device controlled by the microcontroller showing that a smartphone can be used to control arduino robot via Bluetooth.

The Methodology

This Involves making definite decision on hardware and software requirement for the project. To design an enhanced automatic floor cleaner Arduino Nano instead of Arduino UNO.

Secondly, the building of the prototype by making a temporary design through simulation using Proteus Simulator and a physical initial design made considering the focus of the device.

Next is to evaluate the prototype to find out if it meets the aim for creating it and if it does not match, it will be reviewed and then redesigned. This will be followed by the appropriate coding for the system using an appropriate programming language.

This is to be followed by testing of the prototype is made before the robot can be used. It involved testing the software to reduce software and system errors.

Finally, the system is evaluated if what is desired has been made before it can move to the usage stage.

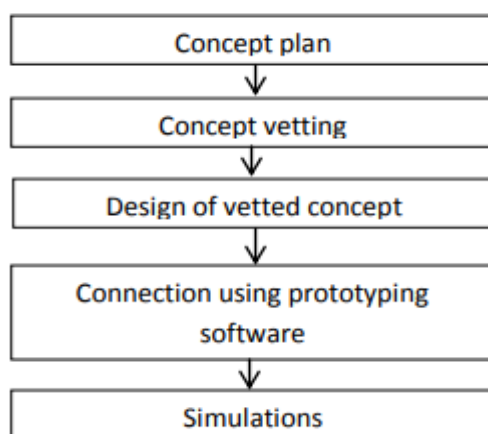

Figure 2: Methodology concept implemented

System Architecture

The figure below shows the proposed system architecture of the Enhanced Automatic Floor Cleaner using Arduino Nano and IR Sensor (EnAutoRobot).

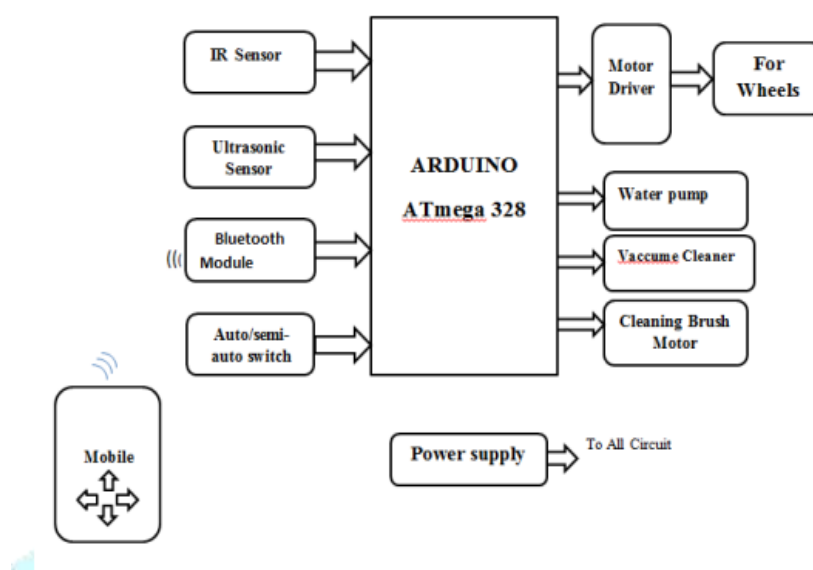

Figure 3: The System Architecture Tiwari et al (2017)

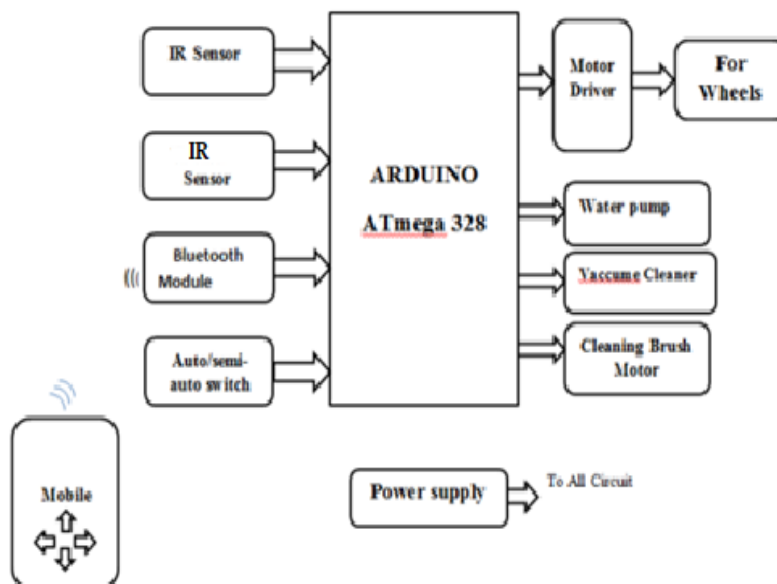

Figure 4: Our Proposed Architecture

The robot contains two types of sensor – IR sensor and Float level sensor. These two sensors are used to detect the obstacle on the floor to be cleaned with the use of the magnetic mechanism of the float level sensor detecting the rise and fall of water /fluid level, this indicates the release of water for cleaning the floor with the aid of the water pump motor. The IR sensor senses any obstacle as it sends signal to the Arduino microcontroller. The Bluetooth module gives the robot the wireless connection and communication between the microcontroller and other components of the system. The system is to be operated using a 12v power supply. It shall be able to cover up to 100m. it shall be made of DC gear motor, L293D Integrated Circuit to drive the wheel motor so that it can easily move about the surface to be cleaned.

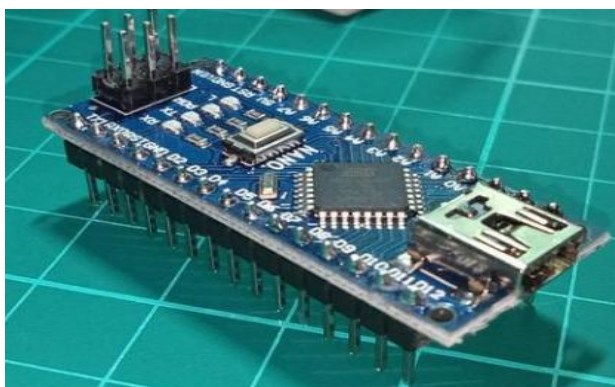

Figure 5: ARDUINO NANO

Required Components:

The hardware and software requirement for the system include the following:

A. Hardware Requirements

1. Arduino Nano (ATmega238)
2. Zero Board

3. Resistors (1, 2, 10 kilo ohms)
4. Bluetooth HC05
5. Infrared Sensor (3 mounts)
6. Motor driver unit
7. Geared DC motor
8. DC motor (4)
9. Water pump motor
10. Vacuum motor
11. Servo motor
12. Power supply
13. Headers (male and female)
14. Others – Screw terminal, wires, mounting bracket for DC motor, vinyl tube, drip infusion system DIS, small plastic bottle – 300ml to serve as reservoir and head of a rotating mop
15. 7805 Voltage regulator

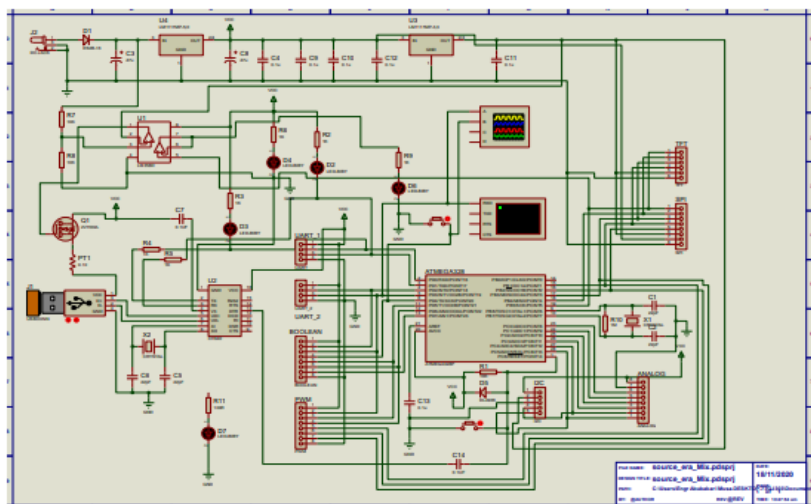

Figure 6: Circuit Schematic Source: Anene, Ibrahim & Abdulhameed, (2021)

System Design

The circuit was initially connected on the Proteus platform. The proposed device was wired using the I/O ports on the Arduino Nano (ATmega328 microprocessor). Applicable connectors were placed according to the design layout using a combination of drill through and surface mount options. The figures following are the Proteus simulator used for the simulation.

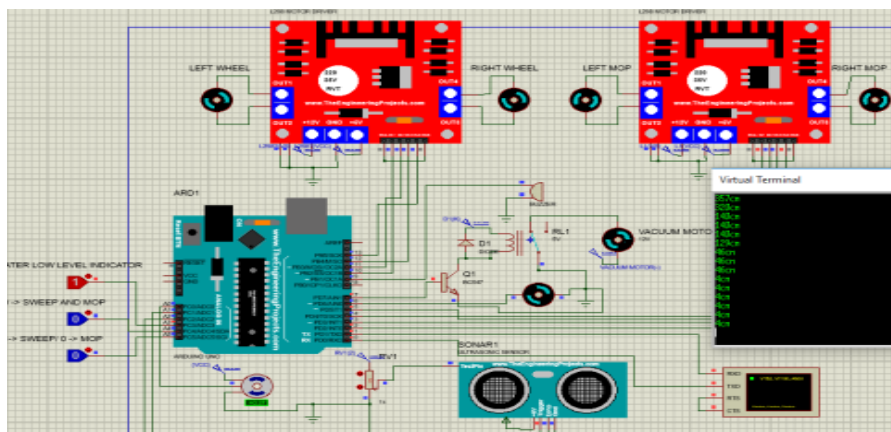

Figure 8: Proteus Simulation mode Agbeyangi et al, 2020

Methodology

To Create a New Circuit for the Arduino Floor Cleaner:

Assembly all the components listed above

Add Components

- Arduino UNO R3
- L298N motor driver
- Two DC motors
- 9V battery or power supply

Next is the Wire Components connections:

Motor Driver (L298N) to Arduino:

L298N Pin	Arduino Pin
IN1	2
IN2	3
IN3	4
IN4	5
ENA	5V (use jumper or PWM pin if speed control needed)
ENB	5V (same as above)
GND	GND

VCC (motor) External 9V battery or 12V supply

5V (logic) 5V from Arduino

DC Motors: Connect Left Motor to OUT1 and OUT2 and then Connect Right Motor to OUT3 and OUT4 and upload the Code through the steps

Click **Code** > **Text** and replace the default code with the one below and then stimulate the project.

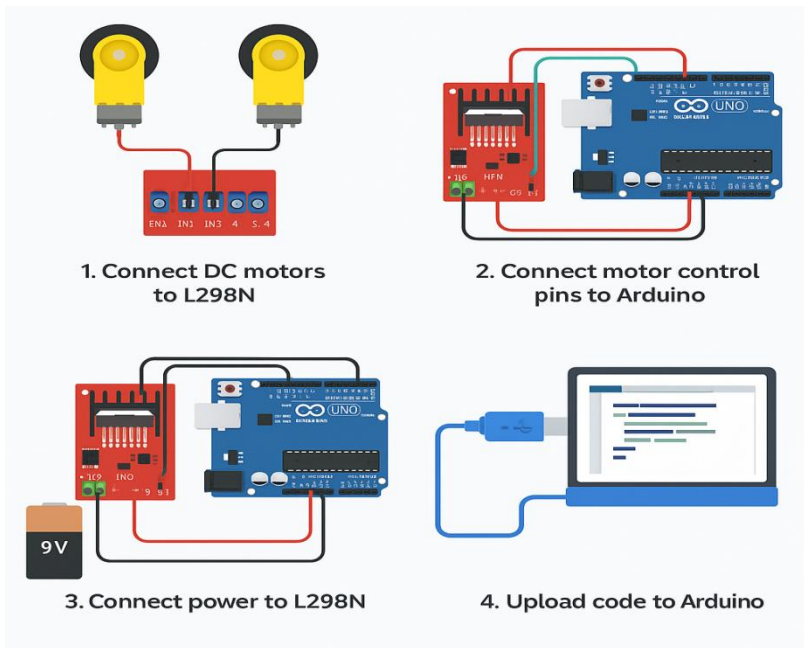

Figure 9: diagramatic steps of connecting components

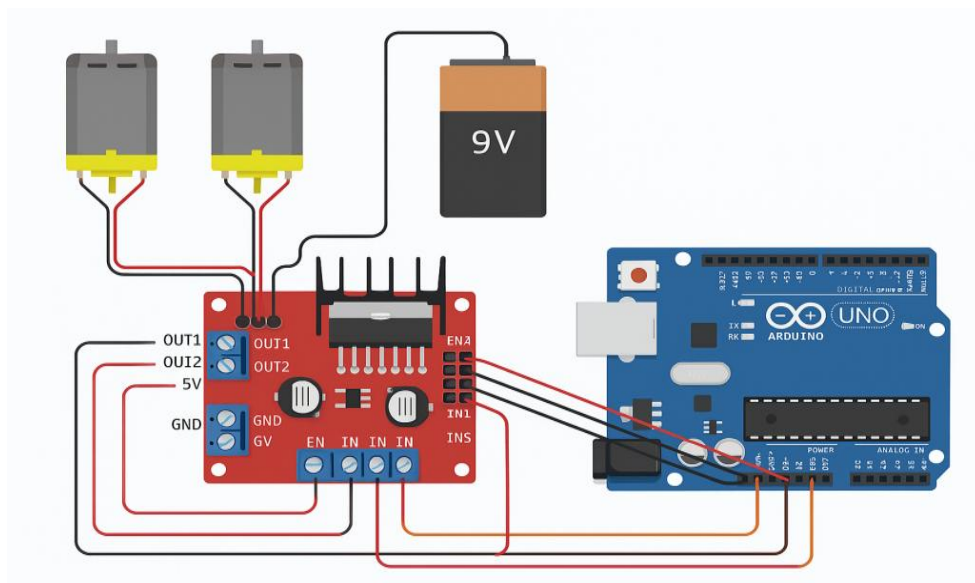

Figure 10: The Arduino Project connected

(i) Click **Start Simulation**

Simulation Coding

for a **simple Arduino** basic **floor cleaner robot** that can:

- Moves **up** (forward),
- Turns **left**,
- Moves **down** 100 cm,
- Turns **right**,

- Moves **up** 100 cm again,
- Repeats the above **5 times**.

```
// Left motor pins
const int leftMotorForward = 2;
const int leftMotorBackward = 3;

// Right motor pins
const int rightMotorForward = 4;
const int rightMotorBackward = 5;

// Movement delay time (in ms)
const int oneMeterTime = 1000; // adjust as per your motor speed
const int turnTime = 400; // adjust for 90-degree turns

void setup() {
  pinMode(leftMotorForward, OUTPUT);
  pinMode(leftMotorBackward, OUTPUT);
  pinMode(rightMotorForward, OUTPUT);
  pinMode(rightMotorBackward, OUTPUT);
}

void loop() {
  for (int i = 0; i < 5; i++) {
    moveForward(oneMeterTime); // move up
    turnLeft();
    moveForward(oneMeterTime); // move down
    turnRight();
    moveForward(oneMeterTime); // move up
  }

  while (true); // stop repeating after 5 loops
}

void moveForward(int duration) {
  digitalWrite(leftMotorForward, HIGH);
  digitalWrite(leftMotorBackward, LOW);
  digitalWrite(rightMotorForward, HIGH);
  digitalWrite(rightMotorBackward, LOW);
  delay(duration);
  stopMotors();
}

void turnLeft() {
```

```
digitalWrite(leftMotorForward, LOW);  
digitalWrite(leftMotorBackward, HIGH); // left motor backward  
digitalWrite(rightMotorForward, HIGH);  
digitalWrite(rightMotorBackward, LOW); // right motor forward  
delay(turnTime);  
stopMotors();  
}  
  
void turnRight() {  
  digitalWrite(leftMotorForward, HIGH);  
  digitalWrite(leftMotorBackward, LOW); // left motor forward  
  digitalWrite(rightMotorForward, LOW);  
  digitalWrite(rightMotorBackward, HIGH); // right motor backward  
  delay(turnTime);  
  stopMotors();  
}  
  
void stopMotors() {  
  digitalWrite(leftMotorForward, LOW);  
  digitalWrite(leftMotorBackward, LOW);  
  digitalWrite(rightMotorForward, LOW);  
  digitalWrite(rightMotorBackward, LOW);  
  delay(200); // short pause between actions  
}
```



Figure 7: An Arduino Automatic Floor Cleaner

conclusions may be made, including the fact that the automatic floor cleaning robot prototype works very well at assisting the community or cleaning staff in keeping floors clean. was investigated by Liang et al (2011). Create a working prototype of an automated floor cleaning robot by utilizing an Arduino Uno microcontroller as a data processor and an ultrasonic sensor as a distance controller. When someone blocks the robot, it will automatically move in the direction the person is not blocking.

References

- Ajay Krishna Gamidi, Saran Reddy Ch, Aravind Yalla & R. Augustian Issac (2018). Obstacle Avoiding Robot Using Infrared and Ultrasonic Sensor. *International Journal of Emerging Technologies in Engineering Research (IJETER)* Volume 6, Issue 10, October (2018) www.ijeter.everscience.org ISSN: 2454-6410
- Akash Rathee, Ishant Jalan, Lakshita Nandwani & Tanya Sharma, (2020). Automatic Smart Floor Cleaning Robot Using Arduino – UNO. *International Journal for Research in Engineering Application & Management (IJREAM)* ISSN : 2454-9150 Vol-05, Issue-12, Mar 2020 280
- Anene E.C. , Ibrahim Abubakar Musa & Abdulhameed Mahmood, (2021). Microcontroller Prototyping Platform with expanded and flexible hardwired I/O resources. *Journal of Electronics and Communication Engineering Research* Volume 7 ~ Issue 6 (2021) pp: 01-08 ISSN(Online) : 2321-5941 www.questjournals.org
- Arulananth T S, Baskar M, P. Hari babu , R. Divya Sree , R.Sanjana, S.Bhavana (2020). IR Sensor Based Obstacle Detection and Avoiding Robot. *Palarch's Journal of Archaeology of Egypt / Egyptology* 17(9). ISSN 1567-214
- Chen G. et al., “Robot Remote Control Using Bluetooth and a Smartphone Augmented System”, Yang D. (eds) Informatics in Control, Automation and Robotics. Lecture Notes in Electrical Engineering, vol 133. Springer, Berlin, Heidelberg, 2011
- Design and Fabrication of Floor Cleaning Machine (2017), *International Journal of Innovations in Engineering Research and Technology [IJIERT]* ISSN: 2394- 3696 volume 4, ISSUE 3, Mar.-2017
- Dipesh Thakur, Nitesh Nikam, Chaitanya Harne, Navnath Thombre, Shailesh Narule, Sonali Tezad , (2018). Multi Function Auto Cleaner, *International Journal of Mechanical and Production Engineering*, ISSN (p): 2320-2092, ISSN(e): 2321-2071 Volume- 6, Issue-3, Mar.-2018, <http://iraj.in> 44 MULTI FUNCTION AUTO CLEANER
- Güven, Y., Coşgun, E., Kocaoğlu, S. Gezici, H, Yilmazlar, E. (2017). Understanding the Concept of Microcontroller Based Systems To Choose The Best Hardware For Applications, *International Journal of Engineering and Science* Vol.6, Issue 9, www.researchinventy.com
- Hadole, S., Kamthe, K., Mugale, S., Dhanure, S. P., Suryawanshi, P. K., & Igave, P. V. (2022). *Auto floor cleaning robot*. *Journal of Emerging Technologies and Innovative Research (JETIR)*, 9(8), 517. <https://www.jetir.org/view?paper=JETIRFP06092>
- Hendriks, B. et al., “Robot Vacuum Cleaner Personality and Behaviour”, *Int J of Soc Robotics* ,Springer Netherlands, 2011

- Liang, Y., Wen, R., Zhang, Z., & Zhu, J. (2011). Dynamic coverage path planning and obstacle avoidance for cleaning robot based on behavior. *2011 International Conference on Electric Information and Control Engineering*, 4952–4956. <https://doi.org/10.1109/ICEICE.2011.5777555>
- Namita Shinde ,Shreya Shrivastava , Vineet Sharma , Samarth Kumar , “ Paper on Arduino Controlled Arduino Based Robot Car” , *International Journal of Industrial Electronics and Electrical Engineering* , ISSN(p) :2347-6982 , Volume 6(3) , March 2013
- Nawghare, S., Maske, A., Pawder, K., Savekar, P., Donode, L., & Gupta, R. R. (2025). Automatic floor cleaning robot using Arduino and ultrasonic sensor. *International Research Journal of Modernization in Engineering Technology and Science*, 7(4), [Article/Page Numbers if available]. <https://www.irjmets.com>
- A. O. Agbeyangi, O. Alashiri, J. O. Odiete & O. A. Adenekan, (2020). An Autonomous Obstacle Avoidance Robot Using Ultrasonic Sensor *The Journal of Computer Science and Its Applications* Vol. 27, No. 1 June 2020
- Shubham Sahu, Dipanjan Paul & Senthilmurugan, S. (2018). Density Based Traffic Signal Control Using Arduino And IR Sensors. *International Journal of Novel Research and Development* Volume 3, Issue 4| ISSN: 2456-4184 IJNRD1804012 (www.ijnrd.org)
- Simple Autonomous Cleaner Robot (2015). *International Journal of Science, Engineering and Technology Research* (c), Volume 4, Issue 5, May 2015.
- Subankar Roy , Tashi Rapden Wangchuk , Rajesh Bhatt , “ Arduino based Bluetooth Controlled Robot” , *International Journal of Engineering and Trends and Technology* , Volume 32 (5) , February 2016
- Thakur, D., Nikam, N., Harne, C., Thombre, N., Narule, S. & Tezad, S. (2018)
- Tiwari, S. Prof. Kotecha, S., Rasal, G. , Shukla, P. & Mandavkar, A. (2017). Arduino Based Cleaner Robot. *International Journal of Engineering Research & Technology* (IJERT), Special Issue - 2017 ISSN: 2278-0181, Published by, www.ijert.org
- Uman Khalid et al , “ Smart Floor Cleaning Robot (CLEAR)” , Ghulam Ishaq Khan Institute of Engineering Sciences and Technology , Pakistan , 2015
- Varsha. P.H et.al., “.Sweeepy –The Smart Floor Cleaner”, 2018 International Conference on Design Innovations for 3Cs Compute Communicate Control, DOI 10.1109/ICDI3C.2018.00035 , pp-124-126, April 2018.
- Yuda Irawan, Muhandi, Rian Ordila & Roni Diandra (2021). Automatic Floor Cleaning Robot Using Arduino and Ultrasonic Sensor. *Journal of Robotics and Control (JRC)* Volume 2, Issue 4, July 2021 ISSN: 2715-5072 DOI: 10.18196/jrc.2485 240 Journal Web site: <http://journal.umy.ac.id/index.php/jrc>